

TG(U)2 series Twin - guide cylinder (Both sides intake) Operating specification and Ordering expression

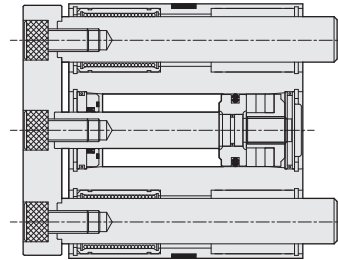

Internal structure



Specification

Unit : (mm)

Item	Bore size	6	10	12	16	20	25	32	40	50	63	80	100
Operation		Double acting											
Fluid		Air											
Pressure range	Kgf/cm ² (kpa)	1.5 ~ 7 (150 ~ 700)											
Max. service pressure	Kgf/cm ² (kpa)	9.5 (950)											
Operating ambient temperature range	°C	0 ~ 60											
Range of service speed	mm/sec	50 ~ 500						50 ~ 350					
Lubrication		Lubrication free											
Port size		M3x0.5		M5x0.8				Rc 1/8		Rc 1/4		Rc 3/8	
Sensor device		With magnet											

Guide type

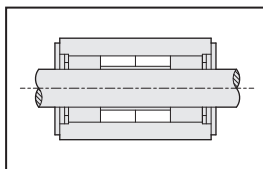
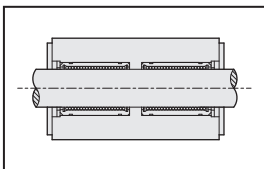

● Linear bearing guide (-U)

● Bush guide (-B)

Sensor switch (Option)

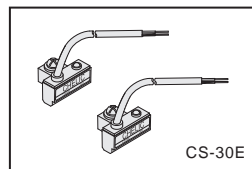

● Sensor switch type CS-30E

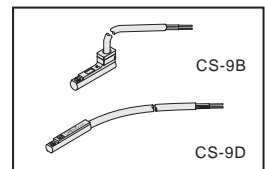

● Sensor switch type CS-9D(B)

Standard stroke

Unit : mm

Bore size	Stroke
Ø6	5、10、15
Ø10	5、10、15、20
Ø12	10、20、30、40、50、75、100
Ø16	25、50、75、100、125、150、175、200
Ø20	25、50、75、100、125、150、175、200
Ø25	25、50、75、100、125、150、175、200
Ø32	30、50、75、100、125、150、175、200、250
Ø40	30、50、75、100、125、150、175、200、250
Ø50	30、50、75、100、125、150
Ø63	30、50、75、100、125、150
Ø80	30、50、75、100、125、150
Ø100	30、50、75、100、125、150

How to select

- **Force** : Select different load required.
(Please refer theoretical force table).
Due to trust areas are different, the pushing and pulling will also be different.
- **Guide type** : ▶ Selection based on the load and its direction.
(Please refer to P.3-9.15 load table).
 - ▶ Linear guide bearing, guide rod is made of hard chrome shaft (SUJ2), suitable for fast moving lower load.
 - ▶ Bush guide bearing, guide rod is made of hard chrome shaft (S45C), suitable for slow moving heavy load.
- **Mounting type** : There are vertical, lift, top, bottom and slide mounting type, etc(Please refer to P.3-9.16).

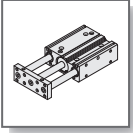

TG(U)2 series Twin - guide cylinder (Both sides intake) Theoretical force and Ordering expression



○ Theoretical force



Bore size (mm)	Piston rod dia (mm)	Action	Piston area (cm ²)	Air pressure (kgf/cm ²)						
				1	2	3	4	5	6	7
6	3	Push	0.28	—	0.5	0.8	1.1	1.4	1.68	1.96
		Pull	0.21	—	0.4	0.6	0.8	1	1.26	1.47
10	5	Push	0.79	—	1.5	2.3	3.1	3.9	4.7	5.5
		Pull	0.59	—	1.1	1.7	2.3	2.9	3.5	4.1
12	6	Push	1.13	—	2.3	3.4	4.5	5.7	6.8	7.9
		Pull	0.85	—	1.7	2.5	3.4	4.2	5.1	5.9
16	8	Push	2.01	—	4	6	8	10.1	12.1	14
		Pull	1.51	—	3	4.5	6	7.6	9.1	10.6
20	10	Push	3.14	—	6	9	12	15	18	21
		Pull	2.35	—	4.7	7.1	9.4	11.8	14.1	16.5
25	12	Push	4.90	—	9	14	19	24	29	34
		Pull	3.77	—	7.5	11.3	15.1	18.9	22.6	26.3
32	16	Push	8.04	—	16	24	32	40	48	55
		Pull	6.03	—	12.1	18.1	24.2	30.2	36.2	42.2
40	16	Push	12.56	12	25	37	50	62	75	87
		Pull	10.55	10	21	31	42	52	63	73
50	20	Push	19.63	19	39	58	78	98	117	137
		Pull	16.49	16	32	49	65	82	98	115
63	20	Push	31.17	31	62	93	124	155	187	218
		Pull	28.03	28	56	84	112	140	168	196
80	25	Push	50.2	50.2	100.5	150.7	201	251.2	301.4	351.7
		Pull	45.3	45.3	90.7	136.0	181.3	226.7	272	317.3
100	25	Push	78.5	78.5	157.0	235.5	314	392.5	471	549.5
		Pull	73.6	73.6	147.2	220.8	294.4	368	441.6	515.2

Note : Above are theoretical data : please take into consideration the frictional resistance and the mechanical efficiency of value should be added calculation before using. (About 70%~80%)

○ How to order

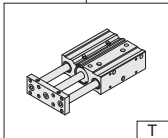
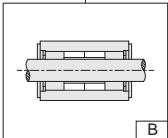
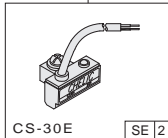
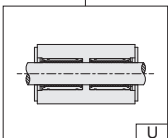
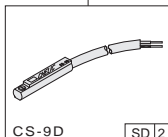
T	G	2	32	×	100	-	SE	2
Model	Guide type		Bore size		Stroke		Sensor Switch	
 T Twin-guide cylinder	 G : Bush guide TG2 = TB2		6 - Ø6 mm 10 - Ø10 mm 12 - Ø12 mm 16 - Ø16 mm 20 - Ø20 mm 25 - Ø25 mm 32 - Ø32 mm 40 - Ø40 mm 50 - Ø50 mm 63 - Ø63 mm 80 - Ø80 mm 100 - Ø100 mm		Ø6 5 - 15 mm Ø10 5 - 20 mm Ø12 10 - 100 mm Ø16 25 - 200 mm Ø20 25 - 200 mm Ø25 25 - 200 mm Ø32 30 - 250 mm Ø40 30 - 250 mm Ø50 30 - 150 mm Ø63 30 - 150 mm Ø80 25 - 150 mm Ø100 25 - 150 mm		 CS-30E SE 2 SE : Sensor switch code (CS-30E) 2 : Number of sensor switch 1 = 1 PCS 2 = 2 PCS	
	 GU : Linear bearing guide TGU2= TU2				Please refer to P.3-9.13		 CS-9D SD 2 SD : Sensor switch code (CS-9D) SB : Sensor switch code (CS-9B) 2 : Number of sensor switch 1 = 1 PCS 2 = 2 PCS	

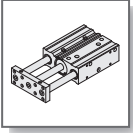

TG(U)2 series

Twin - guide cylinder (Both sides intake)

Operating expression



Allowable horizontal load

Unit : g

Bore size mm	Model	Stroke mm			
		5	10	15	20
Ø6	TB2-6	72	61	51	—
Ø10	TB2-10	245	205	170	150

TB2=TGU2
TU2=TGU2

Unit : kg

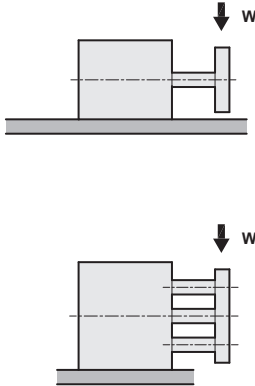

Bore size mm	Model	Stroke mm									
		10	20	25	30	40	50	75	100	125	150
Ø12	TB2-12	2.1	1.8	—	1.5	1.3	1.2	0.9	0.8	—	—
	TU2-12	2.7	2.2	—	1.7	2.1	1.9	1.5	1.3	—	—
Ø16	TB2-16	—	—	2.6	—	—	1.9	1.5	1.3	2.7	2.4
	TU2-16	—	—	2.8	—	—	3.3	2.8	2.3	2	1.7
Ø20	TB2-20	—	—	4.8	—	—	3.4	5.7	4.9	4.2	3.7
	TU2-20	—	—	4.9	—	—	6.5	5.3	4.4	3	2.6
Ø25	TB2-25	—	—	7	—	—	4.7	7.7	6.5	5.6	4.9
	TU2-25	—	—	7.1	—	—	7.2	5.9	5.1	4.2	3.6
Ø32	TB2-32	—	—	—	20	—	18	17.9	15.6	13.8	12.4
	TU2-32	—	—	—	16	—	12	19	15.9	12.3	10.6
Ø40	TB2-40	—	—	—	20	—	18	17.9	15.6	13.8	12.4
	TU2-40	—	—	—	16	—	12	19	15.9	12.3	10.6
Ø50	TB2-50	—	—	—	33	—	28.6	29.2	25.7	23	20.8
	TU2-50	—	—	—	17	—	12.9	21.5	18.1	13.9	12.1
Ø63	TB2-63	—	—	—	33	—	28.6	29.2	25.7	23	20.8
	TU2-63	—	—	—	17	—	12.9	21.5	18.1	13.9	12.1
Ø80	TB2-80	—	—	37	—	—	30.4	34.5	30.9	28	25.6
	TU2-80	—	—	23.5	—	—	15.7	26.3	22.6	19.9	17.8
Ø100	TB2-100	—	—	53.9	—	—	47	41.2	34.3	27.8	25.2
	TU2-100	—	—	47	—	—	31.3	40	33.2	26.1	20.6

Note : Double bearing at guide-rod for stroke length of 75 mm & above.

Max. rotating torque

Unit : N • m

Bore size mm	Model	5	10	15	20
		Ø6	0.09	0.073	0.061
Ø10	TB2-10	0.47	0.39	0.33	0.28

TB2=TGU2
TU2=TGU2

Unit : N • m

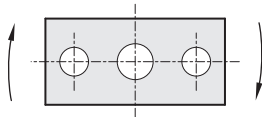

Bore size mm	Model	Stroke mm									
		10	20	25	30	40	50	75	100	125	150
Ø12	TB2-12	0.4	0.3	—	0.28	0.25	0.22	0.45	0.37	—	—
	TU2-12	0.54	0.42	—	0.35	0.3	0.27	0.5	0.42	—	—
Ø16	TB2-16	—	—	0.5	—	—	0.36	0.65	0.55	0.4	0.35
	TU2-16	—	—	0.7	—	—	0.44	0.82	0.7	0.62	0.58
Ø20	TB2-20	—	—	1.02	—	—	0.78	1.95	1.69	1.49	1.28
	TU2-20	—	—	1.28	—	—	0.95	2.23	1.91	1.68	1.47
Ø25	TB2-25	—	—	1.7	—	—	1.31	2.96	2.57	2.26	2.02
	TU2-25	—	—	1.35	—	—	1.03	2.42	2.07	1.82	1.6
Ø32	TB2-32	—	—	—	6.46	—	5.28	5.74	5	4.46	4.01
	TU2-32	—	—	—	3.44	—	2.8	6	5.2	4.6	4.12
Ø40	TB2-40	—	—	—	7.1	—	6.42	5.8	6.3	5.5	4.9
	TU2-40	—	—	—	3.87	—	3.5	3.1	6.7	5.8	5.1
Ø50	TB2-50	—	—	—	13.6	—	11.4	11.9	10.5	9.4	8.5
	TU2-50	—	—	—	5.8	—	4.8	9.3	8.2	7.3	6.6
Ø63	TB2-63	—	—	—	15	—	12.5	13.1	11.6	10.4	9.4
	TU2-63	—	—	—	6.4	—	5.3	10.3	9.1	8.1	7.3
Ø80	TB2-80	—	—	21	—	—	18	23	21	19	18
	TU2-80	—	—	15	—	—	23	22	20	18	16
Ø100	TB2-100	—	—	38	—	—	33	38	33	30	28
	TU2-100	—	—	27	—	—	30	37	34	31	29

Note : Double bearing at guide-rod for stroke length of 75mm & above.

No rotary precision

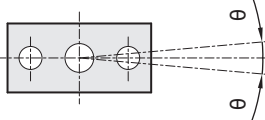

Bore size mm	Ø6	Ø10	Ø12	Ø16	Ø20	Ø25	Ø32	Ø40	Ø50	Ø63	Ø80	Ø100
No rotary precision θ	±0.2		±0.18		±0.17		±0.16		±0.15		±0.1	

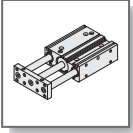

TG(U)2 series Twin - guide cylinder (Both sides intake) Mounting type and Application



Mounting type

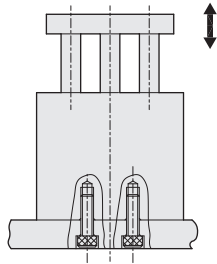

● Lift mounting type

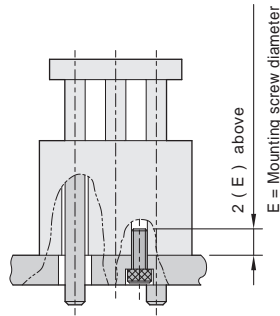

● When Lift mounting , the depth of locking screw

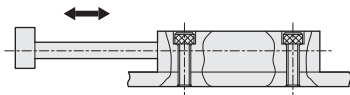

● Top mounting type

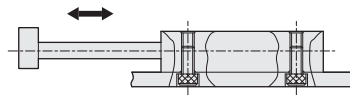

● Bottom mounting type

Multi purpose

● Stopper Cylinder

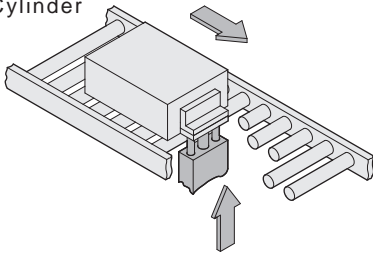

● Press

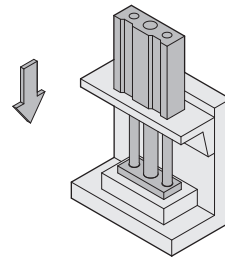

● Lift Cylinder

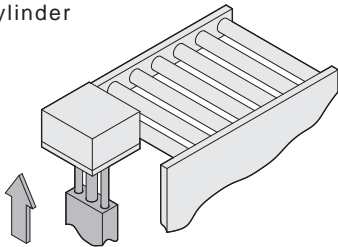

● Robot

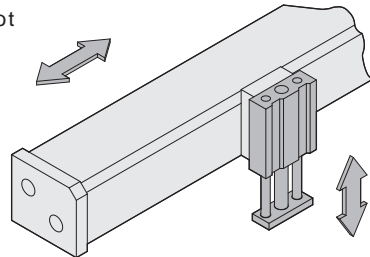

● Pusher Cylinder

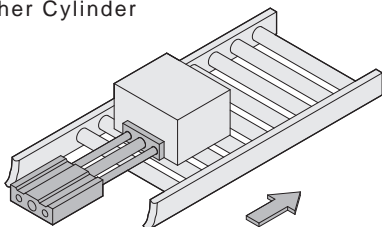

● Clamp Cylinder

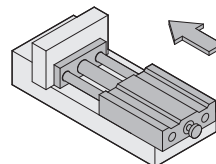

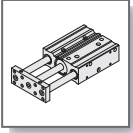

TG(U)2 series Twin - guide cylinder (Both sides intake) External dimension



○ TB(U)2 Ø6 ×

TB(U)2 Ø6 × ST

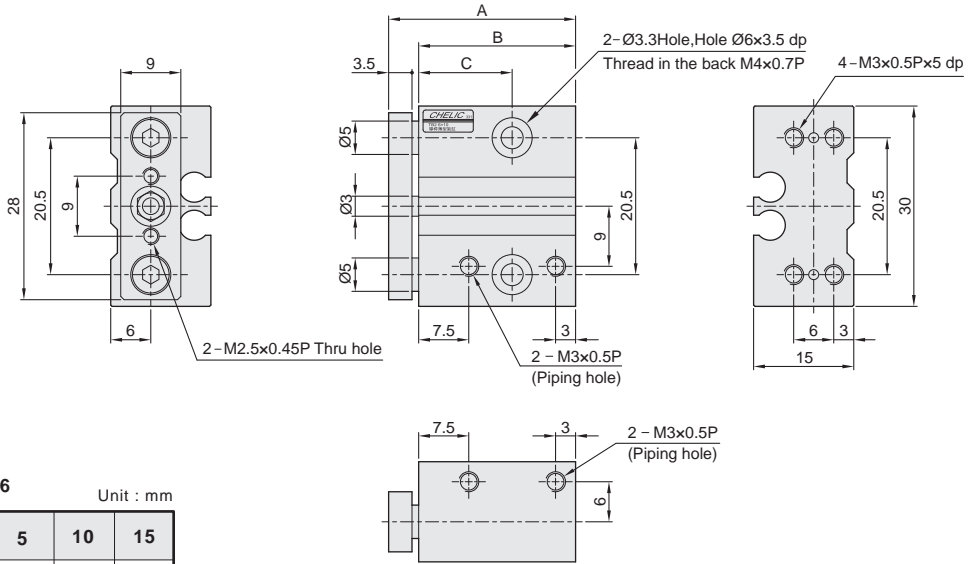

● TB(U)2 Ø6

Unit : mm

Stroke Code	5	10	15
A	28	33	38
B	23.5	28.5	33.5
C	14	19	24

○ TB(U)2 Ø10 ×

TB(U)2 Ø10 × ST

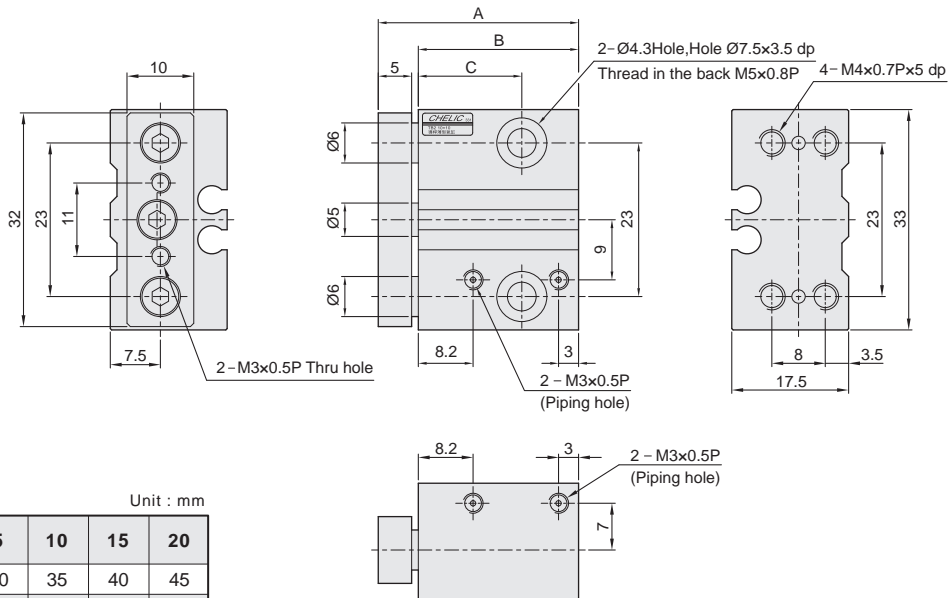

● TB(U)2 Ø10

Unit : mm

Stroke Code	5	10	15	20
A	30	35	40	45
B	24	29	34	39
C	15.5	20.5	25.5	30.5

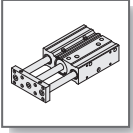

TG(U)2 series

Twin - guide cylinder (Both sides intake)

External dimension



OTB(U)2 Ø20 x

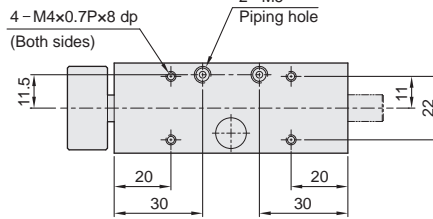
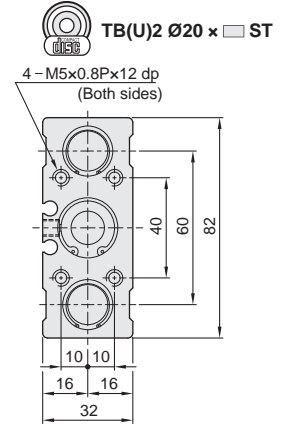
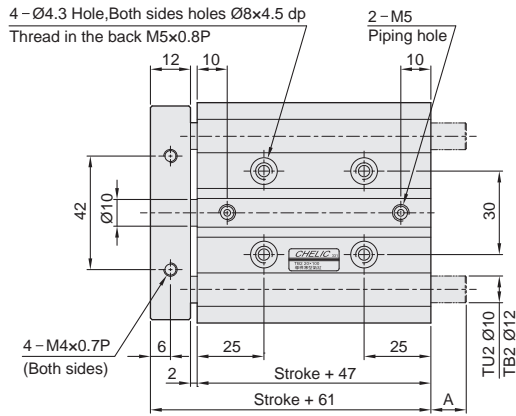
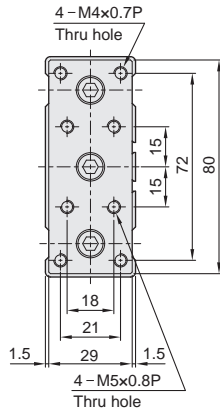

● TB(U)2 Ø20

Stroke Code	25	50	75	100	125	150	175	200
A	0	0	14.9	14.9	14.9	14.9	14.9	14.9

Unit : mm

OTB(U)2 Ø25 x

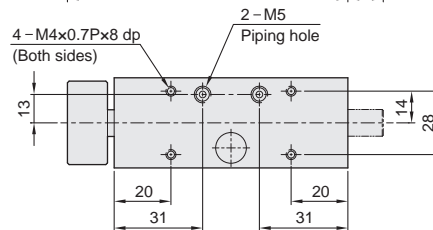
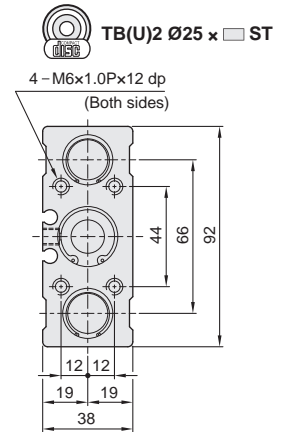
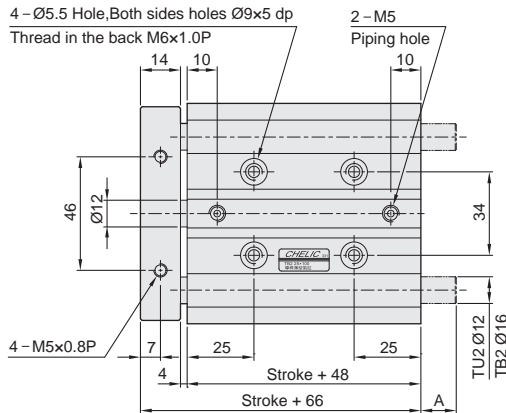
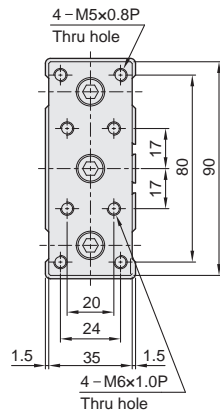

● TB(U)2 Ø25

Stroke Code	25	50	75	100	125	150	175	200
A	0	0	11	11	11	11	11	11

Unit : mm

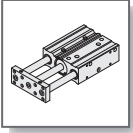

TG(U)2 series

Twin - guide cylinder (Both sides intake)

External dimension



OTB(U)2 Ø50 x

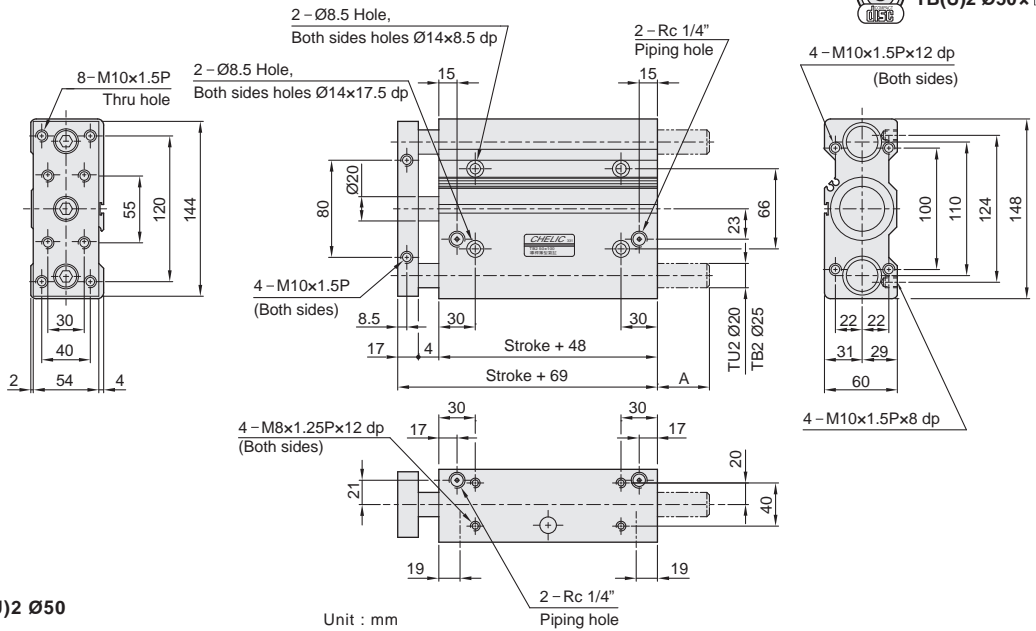

TB(U)2 Ø50x ST

● TB(U)2 Ø50

Unit : mm

Stroke Code \ Stroke	30	50	75	100	125	150
A	0	0	0	49	49	49

OTB(U)2 Ø63 x

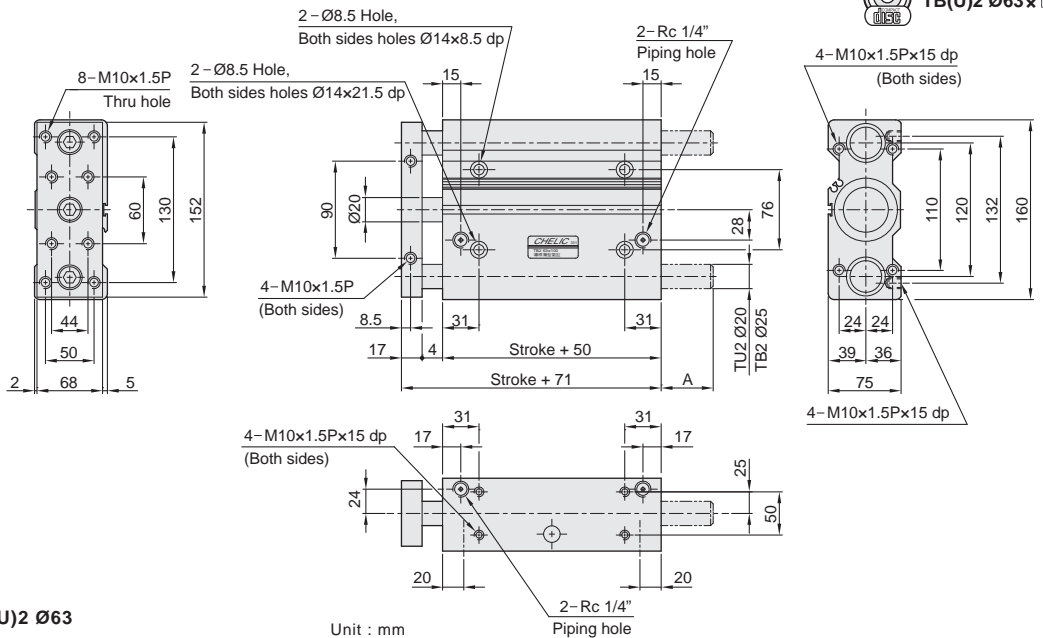

TB(U)2 Ø63x ST

● TB(U)2 Ø63

Unit : mm

Stroke Code \ Stroke	30	50	75	100	125	150
A	0	0	0	47	47	47

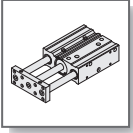

TG(U)2 series

Twin - guide cylinder (Both sides intake)

External dimension



OTB(U)2 Ø80 x



TB(U)2 Ø80 x ST

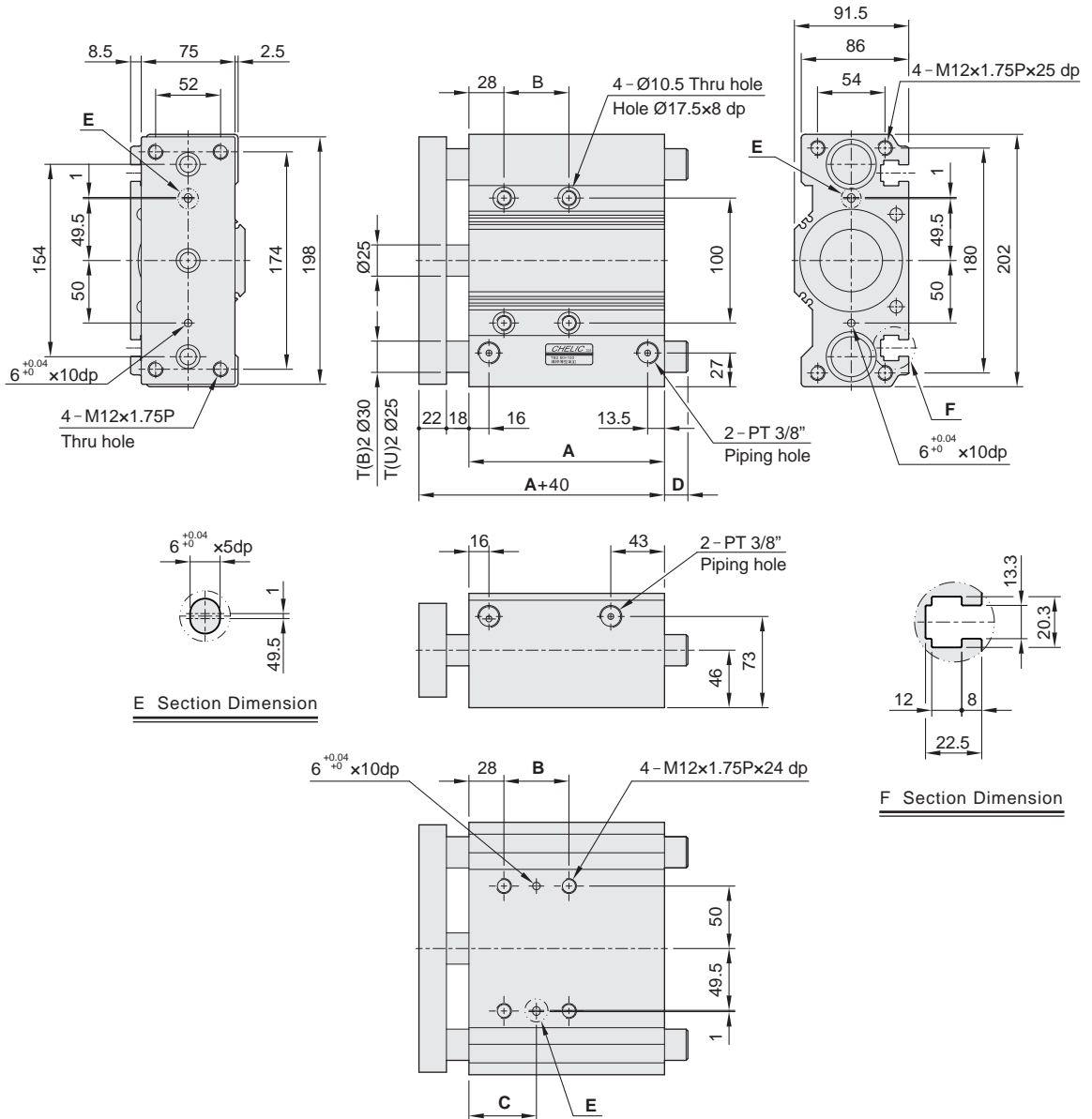

● TB(U)2 Ø80

Unit : mm

Stroke Code	30	50	75	100	125	150
A	81.5	106.5	131.5	156.5	181.5	206.5
B	28	52	52	52	128	128
C	42	54	54	54	92	92
D	10	10	63	63	63	63

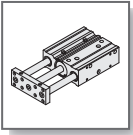

TG(U)2 series

Twin - guide cylinder (Both sides intake)

External dimension



OTB(U)2 Ø100 x

TB(U)2 Ø100 x ST

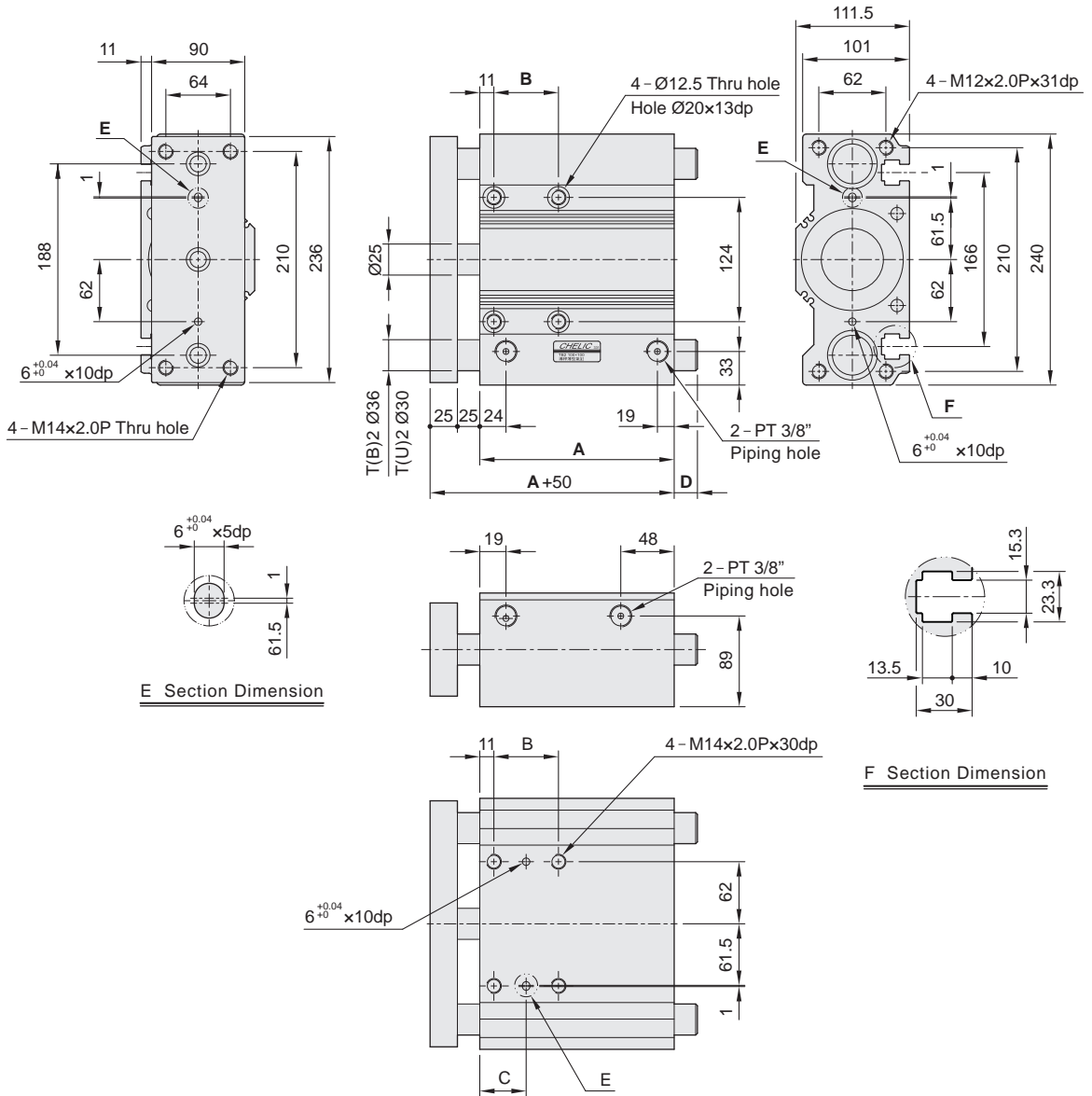

● TB(U)2 Ø100

Unit : mm

Stroke Code	30	50	75	100	125	150
A	91	116	141	166	191	216
B	48	72	72	72	148	148
C	35	47	47	47	85	85
D	5	5	64	64	64	64

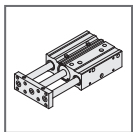

TG(U)2 series (Both sides intake)

Twin-guide cylinder - with sensor switch

Sensor switch installation and Sensing setting

Sensor switch mounting type

TG(U)2 series

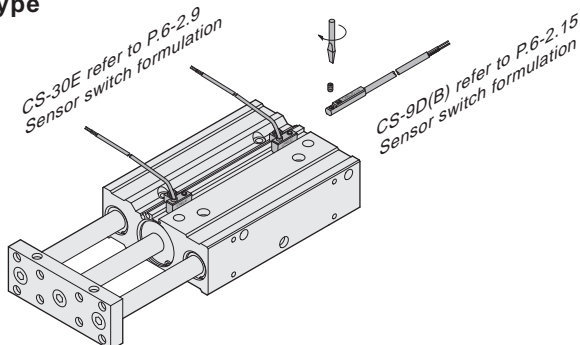

Sensor switch setting and Operating range

CS - 30E

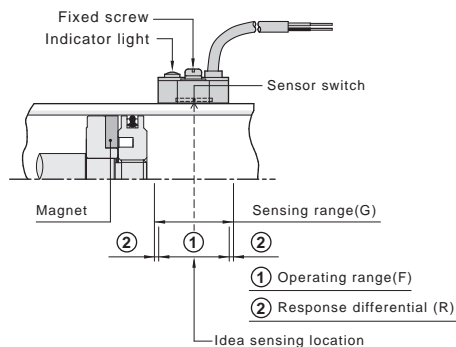

CS - 9D (B)

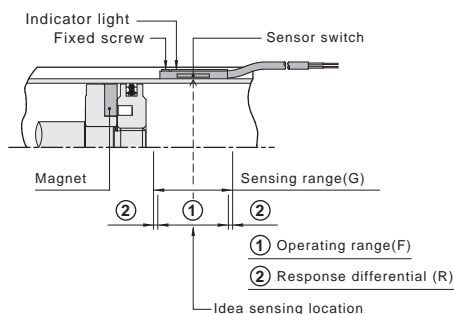

Unit : mm

Sensing range

Sensor switch is fixed on the cylinder body. The magnetic piston head will activate the sensor switch when it enters the operating range.

Operating range

When piston head moves the switch setting and adjustment will be based on the responding range generated by the magnetic field and the switch. (Please refer to the right table)

Connection type

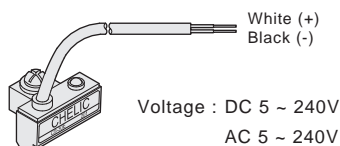

CS - 30E

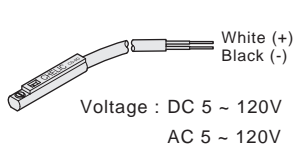

CS - 9D

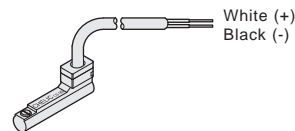

CS - 9B

Model	CS-30E		CS-9D(B)	
	Operating range (F)	Response differential (R)	Operating range (F)	Response differential (R)
Ø 6	—	—	10	1
Ø 10	—	—	10	1
Ø 12	—	—	10	1
Ø 16	—	—	7	1
Ø 20	—	—	8	1
Ø 25	—	—	12.5	1
Ø 32	11	1.2	13	1.2
Ø 40	13	1.2	13	1.2
Ø 50	12	1.4	10	1.3
Ø 63	13	1.4	13	1.4
Ø 80	—	—	13	1.4
Ø 100	—	—	13	1.4